

SHORT-CIRCUITING (EARTHING) SET LV 1 kV for flat conductor single-phase

Models

822.001 - 06 (08,10,15) 1F

TYPE 822.001

General Information

Short-circuiting (earthing) set is designed for short-circuit making and earthing of the circuit in networks with an earthed or insulated node of the nominal voltage of up to 1000 V. The short-circuiting set is delivered together with **one insulating pole** (separable) and **one conductor clamp** and one earthing clamp. Both clamps are connected by Cu cable in transparent insulation. Conductor clamp and earthing clamp are designed for connection to flat conductor. Insulating pole is made of glass fabric laminate which is suitable for its high electrical and mechanical resistance and stability. The pole is ended with socket for conductor clamp handling. It fulfills the requirements on the protection equipment for outdoor use. The set is determined for indoor use, as well as for outdoor use under normal climatic conditions. The handle is provided with the protecting ring (hand guard). Short-circuiting set complies with standards ČSN EN 61230 ed.2, IEC 61230, DIN 46235. It is produced in four models for various short-time withstanding current. It is possible to modify the model at the custom's request.

- 1 - conductor clamp
- 2 - earthing clamp
- 3 - short-circuiting+earthing Cu cable
- 4 - insulating pole
- 5 - socket
- 6 - hand guard
- 7 - handle

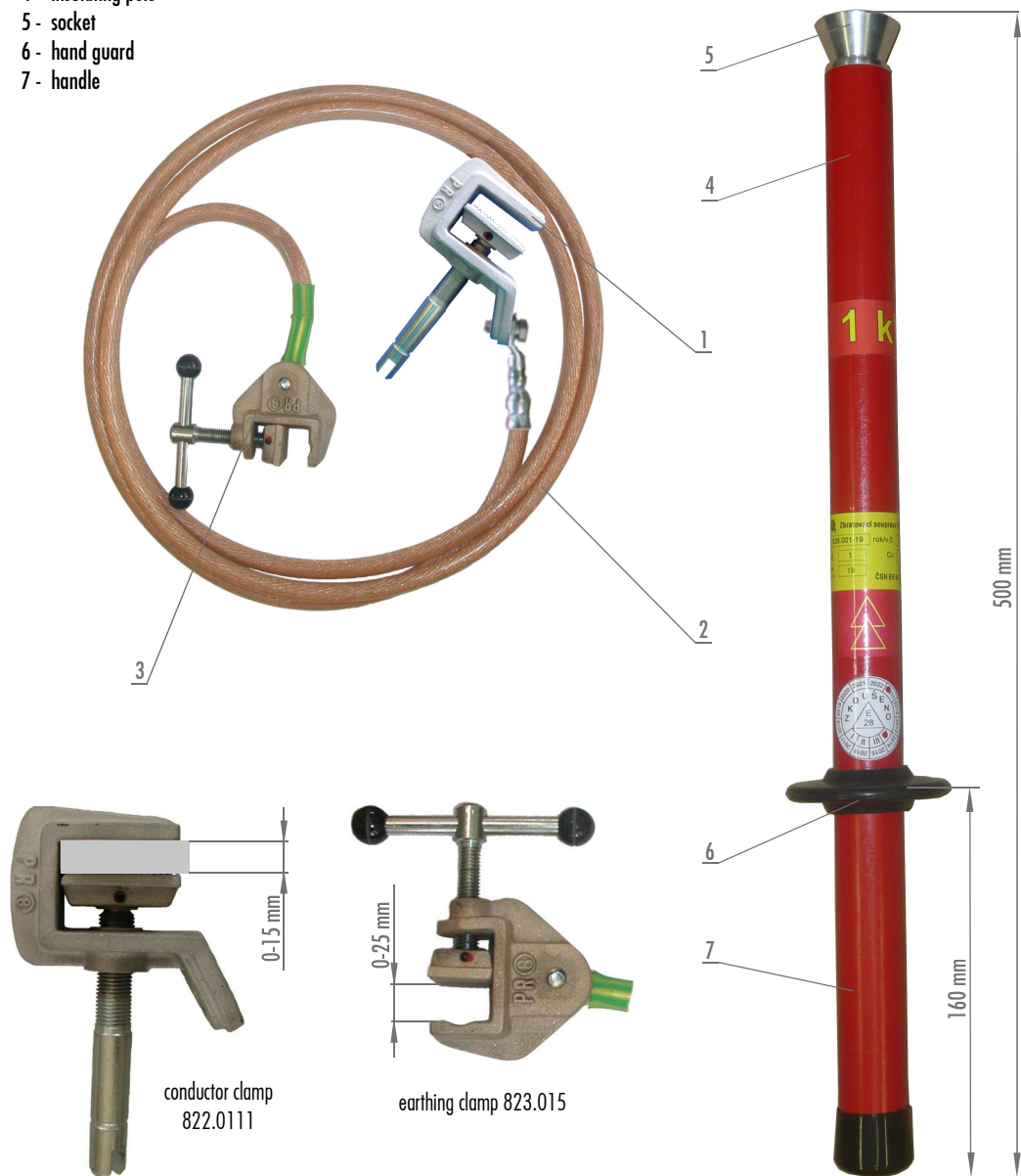

Technical Data

Climatic group	normal -25°C to 55°C	Pole material	glass-fabric laminate for outdoor use
Thickness of short-circuited conductor	15 mm	Cross section of cable	25 (35/50/70) mm ² short-circuiting+earthing
Rated short-time withstanding current	6 (8/10/15) kA/1 s	Length of cable	2000 mm short-circuiting+earthing
Length of pole	500 mm	Tightening of clamps	12 Nm
Length of handle	160 mm	Weight of equipment	2.75 (3/3.3/3.6) kg
Pole diameter	31 mm		

SHORT-CIRCUITING (EARTHING) SET

LV 1 kV

for flat conductor
single-phase

TYPE 822.0010

1.0

Directions for use

Before using the set, it is necessary to use a voltage detector to be sure that the traction is without tension.

The short-circuiting equipment is fixed in this way:

- 1) fix the earthing clamp to the earthing conductor or to the metallic grounded construction
- 2) slip the conductor clamp to the socket so that the pivot in the socket put together with the cut hole in the screw mechanism of the clamp
- 3) rotate the insulating pole (while holding the clamp) until the clamp jaws open according to the thickness of the short-circuited flat conductor
- 4) put the clamp onto the flat conductor
- 5) rotate reverse by the insulating pole to constriction of the clamp
- 6) pull the pole backward from the conductor clamp to release the pole
- 7) when removing the clamp, proceed reversely

Make sure the clamp is tightened properly. The tightening torque must not exceed 12 Nm.

The short-circuiting set should only be used on electrical facilities with nominal voltage for which it is designed.

The instructions for use should be incorporated into the local operating and safety regulations.

The set may only be used by qualified personnel.

Maintenance and storage

The set must be kept in good technical condition. Make sure that the set is stored in the way to keep it dry and to prevent any mechanical damage. Perform a visual check before each use. At least once a year, it is necessary to perform a thorough check of the whole set, including cleaning and tightening all the connecting points.

For common cleaning of the poles use damp cloth, for more resistance dirt use technical alcohol. Do not use any organic solvents or any substances which may have a decolorizing effect.

!!! The set must be eliminated or proved again its right functionality, when a short-circuiting current has already gone through short-circuiting current !!!

Testing

The set is type-tested according to valid standards by the authorised laboratory. Each set is separately tested piece by piece before expedition and labeled too. The label includes the test date (quarter/year) and the number of the authorised laboratory.

Packing

The cables with clamps are supplied in a water-resistant carry bag. The insulating poles are wrapped in a transparent plastic foil. There is enclosed the function description and the directions for use, the Certificate about quality and completeness of product and product test.

Guarantee

The guarantee period is 24 months long and starts on the day the product is delivered to the customer. It applies to any defects probably caused by the manufacture. The guarantee does not cover any defects resulting from improper use, unprofessional handling, or unsuitable storing.

2.0

3.0

4.0

5.0